

Contents in this document may change without prior notice.
Please obtain the delivery specification for the final design.



7.0" Wide (WVGA)

Projected capacitive Touchscreen Module with LCD

Basic Set

TK-B Series

Model: TK-BPA07BWV-01A4

Product Specification

DMC Co., Ltd.

<https://www.dush.co.jp/english/>

Table of Contents

1	Summary	2
2	Product Model	2
3	Packaging Specification	3
3-1	Grouped packaging	3
3-2	Individual Packaging	4
4	Module Specification	5
4-1	Function	5
4-2	General Specification	6
4-3	Environment	6
4-4	Mechanical Specification	6
4-5	Touchscreen Controller	6
4-6	Touchscreen Driver	6
4-7	HDMI Board Support Timing	7
4-8	User Interface Specifications	7
4-8-1	Part Names	7
4-8-2	Image Input (HDMI) I/F	8
4-8-3	12VDC Power Input I/F	8
4-8-4	Touchscreen Control USB I/F	8
5	Product Label	9
6	Compliant Standards	9
6-1	RoHS	9
7	Appearance inspection standard	9
8	Option Items	9
9	Connecting Method	10
9-1	Connecting Each Cable to User I/F of HDMI Board	10
9-2	Connecting Each Cable to User I/F of Touchscreen Controller	10
10	Touchscreen Calibration	11
10-1	Projected Capacitive Touchscreen	11
11	Terms of Use	12
11-1	Installing Module	12
11-2	Precautions for Use of LCD	12
11-3	Precautions for Projected Capacitive Touchscreen	12
11-4	Precautions for Static Electricity	13
11-5	Operating Precautions	13
11-6	Storing Precautions	13
11-7	Handling Precautions	13
12	Warranty	14
13	Production Discontinuance	14
14	Other	15
	Appendix	
	• Outline Drawing	
	• Glass/Glass Structure Projected Capacitive Touch Screen, Mounting Guidance	
	• Touch Screen Controller Specification: DUS1000 Product Specification	
	• Appearance inspection standard	
	(LCD Modules with Capacitive Glass Sensor Touchscreen)	

1 Summary

This is a “TK series Basic Set” with 7.0" Wide projected capacitive touchscreen sensor, controller, LCD(Liquid Crystal Display), and HDMI board put together in a sheet metal chassis.

2 Product Model

Model	Specification			
	LCD size (Resolution)	Touchscreen Type	Bonding method	Set Type
TK-BPA07BWV-01A4	7.0" Wide (WVGA)	Projected capacitive	Air-bonding *1	Basic Set

*1. Bonding of LCD and touchscreen with double-sided tape.

3 Packaging Specification

Depending on the number of shipments, individual packaging may be used instead of grouped packaging.

3-1 Grouped packaging

Box	Contents	Specification	Size (W x D x H)
A	TK-BPA07BWV-01A4	Grouped packaging (5units/box) *	External Dimension: 302 x 302 x 280

* May not be as specified according to the quantity shipped.

• Grouped Packaging Configuration(A)

No.	Name	Qty
①	TK-BPA07BWV-01A4 (placed inside anti-static, air-cushion bag)	5
②	Individual box	5
③	Outer box	1
④	Top Pad	2
⑤	Packaging label	5
⑥	Grouped packaging label	1

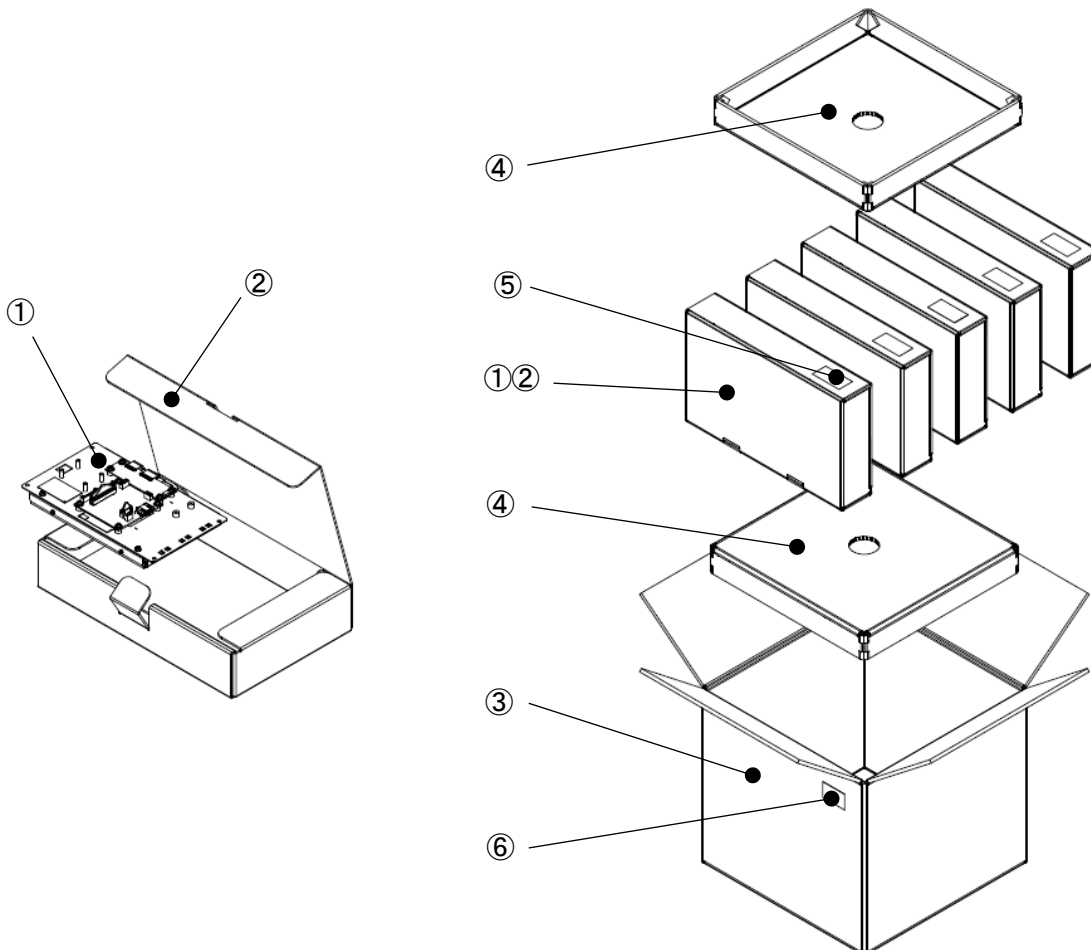

3-2 Individual Packaging

Box	Contents	Specification	Size (W x D x H)
B	TK-BPA07BWV-01A4	Individual packaging (1units/box)	External Dimension: 287 x 176 x 55

• Grouped Packaging Configuration(B)

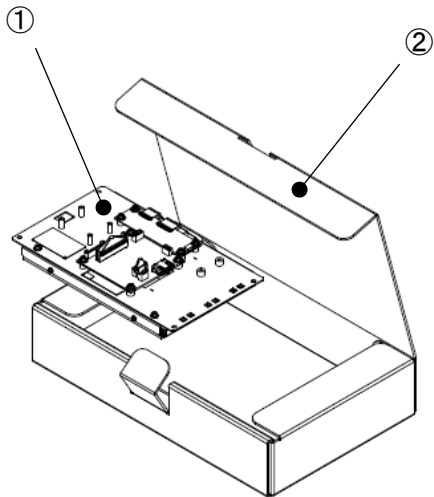

No.	Name	Qty
①	TK-BPA07BWV-01A4 (placed inside anti-static, air-cushion bag)	1
②	Outer box	1
③	Packaging label	1

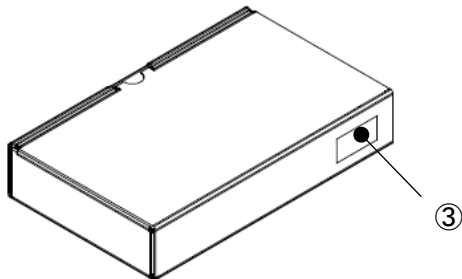

4 Module Specification

4-1 Function

Item		Specification	units	
LCD	Display device	7.0" Wide TFT LCD	-	
	Display area (Active area)	152.4(W) ×91.44(H)	mm	
	Pixels	800(W) ×480(H)	-	
	Pixel pitch	0.1905(W) ×0.1905(H)	mm	
	Color	16.7M	colors	
	Brightness (Typ.)	445	cd/m ²	
	View angle (Typ.)	Vertical (Upper/Lower)	89 / 89	deg.
		Horizontal (Left/Right)	89 / 89	
	Interface	LVDS	-	
	Backlight method	LED, with backlight driver	-	
	Backlight life *1	Min. 50,000	hours	
Touchscreen	Touchscreen type	Projected Capacitive	-	
	Input method	Finger	-	
	Maximum simultaneous input point	5 point *2	-	
	Operating life(Continuous Typing)	50 million times(finger input)	-	
	Communication Method	USB 2.0	-	
	Supporting OS *3	Microsoft® Windows® 10/11 (32bit/64bit)	-	
HDMI board	Input image port	HDMI (does not support HDCP)	-	
	Input Signal	Digital	HDMI 1.3b	
		Horizontal scan cycle	30K - 80K	Hz
		Vertical scan cycle	50 - 75	Hz

*1. Time until brightness declines by 50% from the initial value at maximum brightness in ambient temperature of 25°C.

*2. Operation may become unstable depending on the installation environment. Please perform calibration according to the instructions in "[Section 10. Touchscreen Calibration](#)".

*3. Please contact us for information regarding OS other than Windows.

4-2 General Specification

Item		Specification
Power	Input power voltage	12VDC
	Voltage tolerance	12VDC±5%
	Power consumption *	Max. 4.0W

* Excluding touchscreen controller.

Note: If the capacity of the power supply used is large, the drop in voltage when it is turned off will be gradual. When restarting, please turn on the power again after the power supply voltage becomes 0V.

4-3 Environment

Item	Specification
Ambient operating temperature (Inside cabinet and display side)	0°C to 55°C
Ambient storage temperature	-20°C to 70°C
Ambient operating humidity	10%RH to 85%RH (Non-condensing. Wet-bulb temperature is 39 °C or less)
Ambient storage humidity	10%RH to 85%RH (Non-condensing. Wet-bulb temperature is 39 °C or less)
Dust	0.1mg/m ³ or under (Conductive dust is prohibited)
Corrosive Gas	Corrosive gas is prohibited
Pollution Degree	Pollution Degree 2, for indoor use

4-4 Mechanical Specification

Item	Specification
Mass	Approx. 550 g
External dimensions (excluding protruding parts)	194(W)×112(H)×33(D) mm

4-5 Touchscreen Controller

Please refer to the attached touchscreen controller specification for details.

4-6 Touchscreen Driver

To obtain the touchscreen driver (DMT-DD), please download it from the following site.

URL: <https://www.dush.co.jp/english/download/>

Download > Driver-App > Touchscreen Related > Touchscreen Driver.

For DMT-DD installing directions, please refer to the User's Guide included in the downloaded files.

4-7 HDMI Board Support Timing

No	Resolution	Refresh Rate
1	640×480p	60/75Hz
2	800×480p	60/75Hz

4-8 User Interface Specifications

4-8-1 Part Names

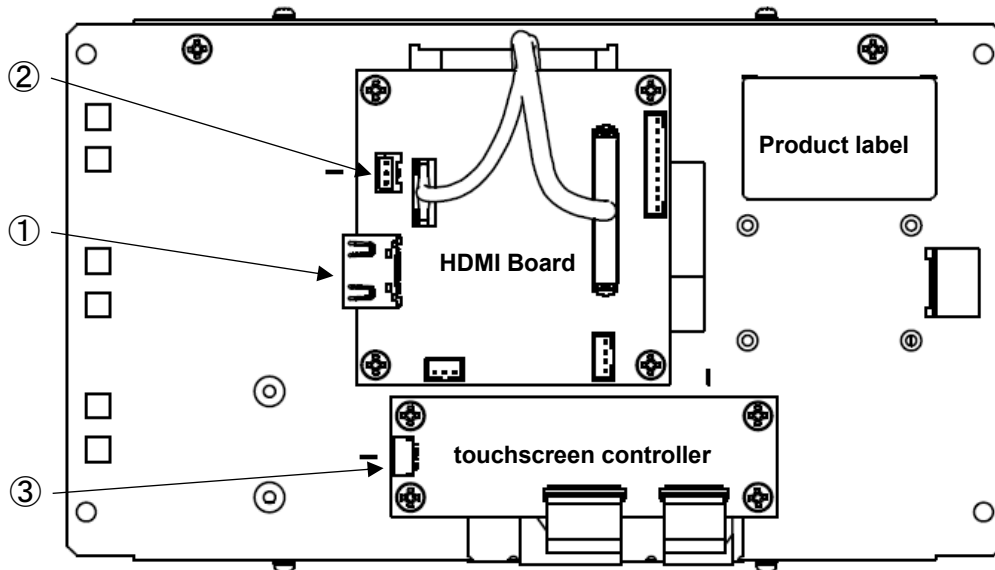

No.	Interface Name
①	Image input (HDMI)
②	12VDC Power input (Nylon connector)
③	Touchscreen control USB (Nylon connector)

Note: Use of other connectors not listed is prohibited. They are for internal adjustments only and may be excluded without prior notice.

4-8-2 Image Input (HDMI) I/F

Connector No.: HDMI Board CN8

Interface: HDMI Type A

Note: HDMI standard compliant

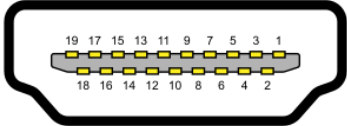
PIN No	Signal Name	PIN No	Signal Name	Schematic Diagram
1	TMDS Data2+	11	TMDS Clock Shield	
2	TMDS Data2 Shield	12	TMDS Clock-	
3	TMDS Data2-	13	CEC (NC)	
4	TMDS Data1+	14	Reserved	
5	TMDS Data1 Shield	15	DDC Clock	
6	TMDS Data1-	16	DDC Data	
7	TMDS Data0+	17	DDC GND	
8	TMDS Data0 Shield	18	+5V Power	
9	TMDS Data0-	19	Hot Plug Detect	
10	TMDS Clock+	-	-	

4-8-3 12VDC Power Input I/F

Connector No.: HDMI Board CN1

Interface: +12VDC Input

Connector: MK242151P3(ZONE TECH TECHNOLOGY)

Note: Equivalent to B03B-PASK-1 (JST)

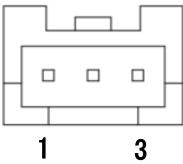
PIN No.	Signal Name	Schematic Diagram
1	+12V	
2	GND	
3	GND	

4-8-4 Touchscreen Control USB I/F

Connector No.: Touchscreen Controller (DUS1000) CN3

Interface: USB2.0

Connector: SM06B-SRSS-TB (JST)

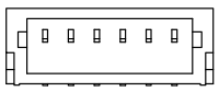
PIN No.	Signal Name	Schematic Diagram
1	VBUS	
2	D-	
3	D+	
4	GND	
5	RESETn	
6	GND	

Note: Please refer to the attached touchscreen controller specification for details.

5 Product Label

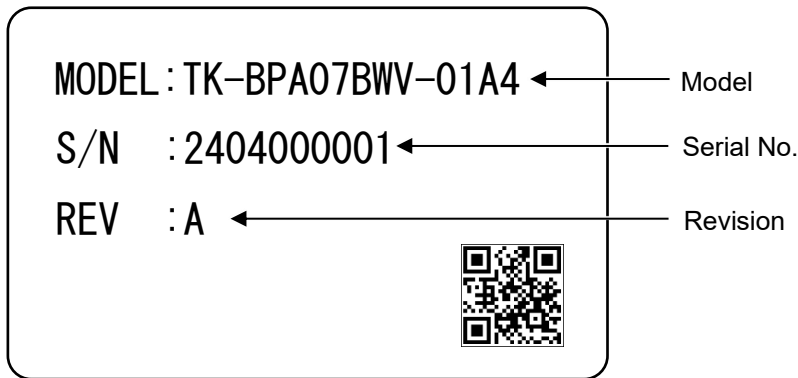

Above is an image example of the product label.

Below information will be indicated on the actual product.

- Model: Product Model
- Serial No.: 10 digit control number
- Revision: Alphabets (A to Z) according to the product revision

6 Compliant Standards

6-1 RoHS

Compliant to EU RoHS directives.

7 Appearance inspection standard

Please refer to "Appearance inspection standard(LCD Modules with Capacitive Glass Sensor Touchscreen)" (22G4GX-00002E) for standards.

8 Option Items

■Controller Cable

Model	Specification
DUS-10USB	USB cable for connecting host (USB-TypeA) and touchscreen controller (L:1800mm).

9 Connecting Method

9-1 Connecting Each Cable to User I/F of HDMI Board

(1) Connecting the HDMI cable and the Power cable.

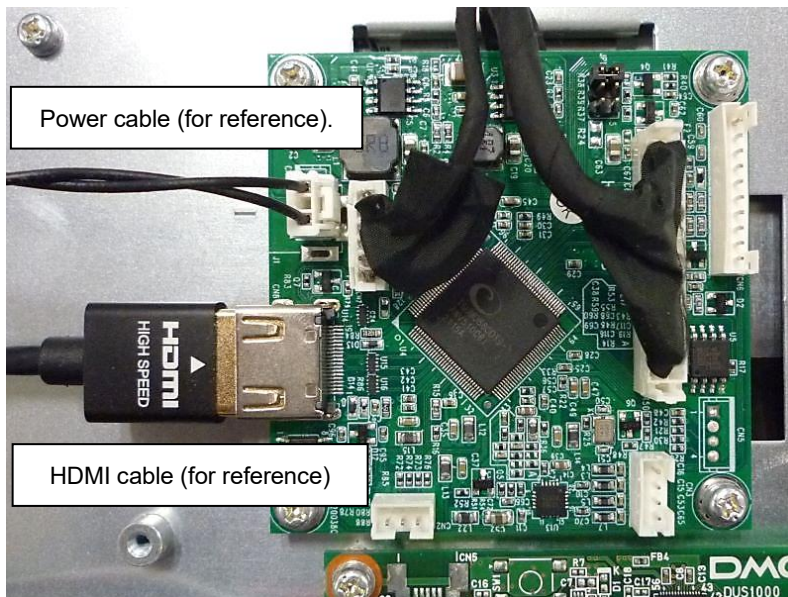

* Please insert securely.

* HDMI cable/ Power cable not included.

9-2 Connecting Each Cable to User I/F of Touchscreen Controller

(1) Connecting the USB cable.

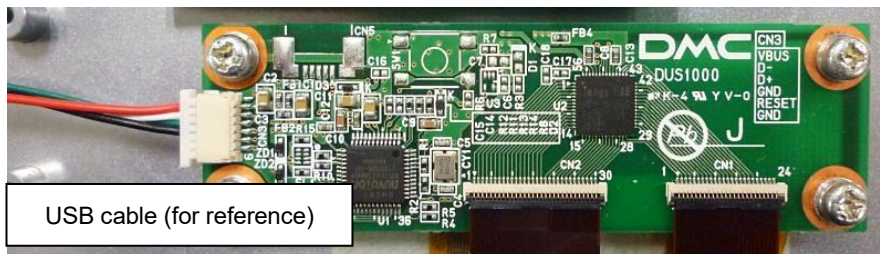

* Please insert securely.

* USB cable not included.

* The cable in the photo is an optional item (DUS-10USB).

10 Touchscreen Calibration

Touchscreen operations may become unstable depending on the installation environment due to its characteristics. To use it correctly, please perform calibration when building into a device.

Install DMT-DD from "[4-6. Touchscreen Driver](#)" when calibrating.

10-1 Projected Capacitive Touchscreen

[TPOffset] ...Sensitivity calibration.

- (1) Start DMT-DD.
- (2) Open [Touchscreen Maintenance] via [Basic Setting] > [Hardware Setting] and click [Open].

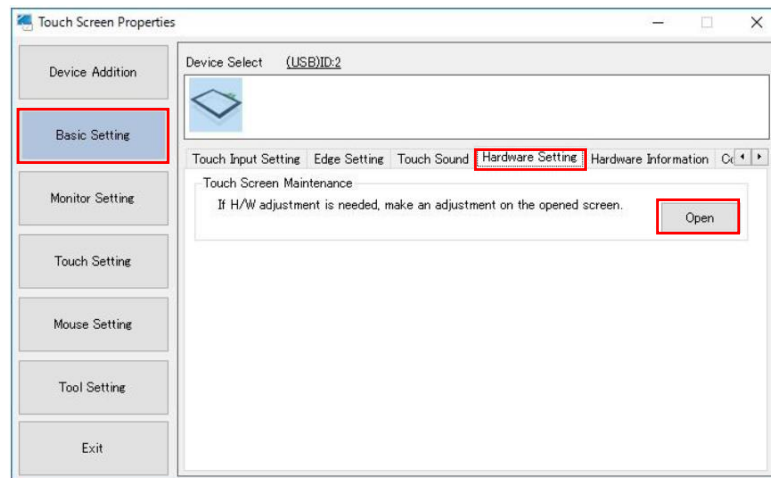

- (3) Hardware calibration is complete when [Dev.0] [DONE] [0x00] turns green.

Maintenance Tool Screen (Example)

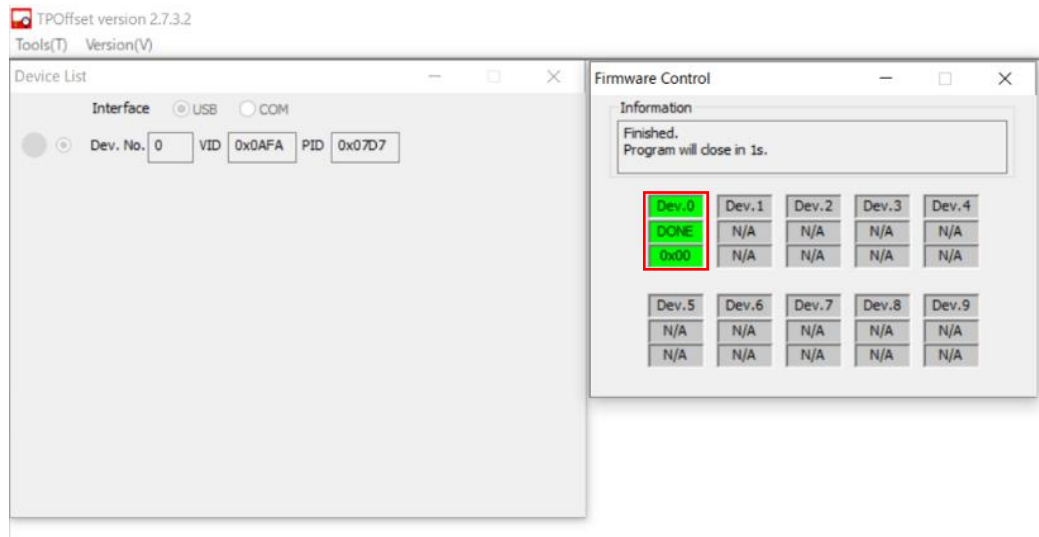

- * [Setup Tool] cannot be operated while the [Maintenance Tool] is running.
- * Please do not touch the touchscreen when calibration is being performed.
- * This tool will automatically terminate.

11 Terms of Use

11-1 Installing Module

- (1) Make sure there are no warping and twisting when installing.
- (2) Make sure the specified temperature and humidity between the module and structure or parts is taken into consideration to secure ventilation.
- (3) Take anti-static measures such as wearing grounding arm bands during assembly.
- (4) To prevent malfunction or damage, make sure the connector of connecting cable is inserted securely.

11-2 Precautions for Use of LCD

- (1) The LCD contains irritants inside. If by any chance the liquid should flow out due to damages and come in contact with the skin, wash immediately under running water for more than 15 minutes and consult a physician.
- (2) LCD may have uneven brightness depending on the contents displayed. Please note that this is not a malfunction.
- (3) LCD elements may have spots (black spots/ bright spots). This is a characteristic of the LCD and not a malfunction.
- (4) When screen is viewed outside the viewing angle, the color displayed may appear to change. This is a basic characteristic of the LCD and not a malfunction.
- (5) When the same screen is displayed for a certain long period of time, the image may remain as an afterimage. This is a basic characteristic of the LCD.

In order to avoid afterimages, use a screensaver or other similar functions to periodically change the display and avoid displaying the same image for a long period of time.

11-3 Precautions for Projected Capacitive Touchscreen

- (1) If elements that change ambient environments or electric fields (capacitors with large capacity, power units, and materials with high permittivity such as metals) are set close to the product, it might have impact to the coordinate detection. Make sure to keep a good distance from the above unstable elements as much as possible when designing.
- (2) Due to the characteristics of the touchscreen, its functions might become unstable according to the environment it is installed. For correct operations, perform sensitivity sensor calibration when building into a device. Also if at any time the touchscreen operation become unstable due to changes in environment or installation conditions, perform sensitivity sensor calibration.
- (3) The touchscreen surface is made of glass. Glass becomes easy to break if scratched. Please handle with care and avoid glass from coming in contact with other glass and hard objects.
- (4) Touchscreen may not operate correctly when there is moisture on the surface. When moisture is detected on the touchscreen surface, please wipe it dry before use.
- (5) Handle When designing applications, consider the fact that area slightly outside the display might be read as a coordinate due to the characteristics of the touchscreen when touched.
- (6) Be careful when handling the end face of the glass as it is easily injured.

11-4 Precautions for Static Electricity

- (1) Static Electricity may cause damages. Please take sufficient measurements when handling.
- (2) Take anti-static measures such as wearing grounding arm bands during assembly.

11-5 Operating Precautions

- (1) When used outside the specification standards, it may significantly affect product quality and service life, such as degradation of display quality and generation of air bubbles. Please be sure to use within the specifications.

11-6 Storing Precautions

- (1) When storing the module, please avoid areas of high temperature and humidity. Especially when storing for a long period of time, make sure to store in a place that is not be exposed to direct sunlight and/or fluorescent lighting.
- (2) Please store the module in a condition where it is not subject to excessive load.

11-7 Handling Precautions

- (1) Do not leave the product in an environment with high temperature for a prolong period. Make sure to avoid high humidity especially when the temperature is above 40°C. Failing to do so may cause polarizing plate deterioration, peeling, and/or bubbles to form.
- (2) If the surface of the polarizing plate becomes dirty, wipe it lightly with a soft material such as cotton cloth moistened with a small amount of ethyl alcohol.
- (3) Make sure to wipe off immediately any form of liquids to avoid deformation, discoloration or fading of the polarizing plate.
- (4) Condensation on the polarizing plate during testing is prohibited to prevent staining, discoloration, or spots to form on the plate.
- (5) Disassembling and/or changing the volume of the module is prohibited. Doing so may cause malfunction and failure to perform correctly.
- (6) This product is intended for use in general electronic equipment and is not intended for use in special environments such as corrosive gas atmosphere. If use in a special environment is anticipated, please evaluate the product thoroughly or take precautions not to expose the LCD to corrosive gases, etc.
- (7) This product is intended for use in standard applications (office equipment, industrial, communication, and household equipment, etc.). Do not use the products for special applications that require extremely high reliability (e.g., aerospace, nuclear power control, medical applications for life support, etc.) or where malfunctions or failures may directly cause injuries to the human body.
- (8) Do not rub or press the product with hard or sharp objects.
- (9) Keep away from flames/fire.
- (10) Avoid wiping the product with excessive pressure.
- (11) Avoid locally rubbing the product with strong pressure. It may cause damage to the function of the touchscreen.
- (12) When operating the product, please avoid striking it with a hard object.
- (13) Do not forcibly fold or bend the product.

- (14) When storing the product, use the packing box and keep the product within the specified storage temperature and humidity and in an environment where it is free of excessive pressure and loads.
- (15) Avoid using and storing the product where it can be exposed to or can come in contact with liquids, organic solvents, and acidic atmosphere.
- (16) Avoid using the product in direct sunlight.
- (17) Do not pull off or disassemble the product.
- (18) When handling the product, hold the main unit and not the touchscreen FPC (tail).
- (19) EMC (EMS, EMI), please conduct overall evaluation and confirmation after the product has been installed in your equipment.

12 Warranty

The warranty period is limited to 12 months (1 year) from the date of shipment. Any defects that occur upon normal use under conditions specified herein will be repaired (factory repair) free of charge. (Warranty for any repair needed to the same repaired part of the same product is three months.)

You will be liable for all repair fees even within the warranty period for any conditions listed below.

- (1) Any malfunctions, defects, and/or damages that occurred during transport, transfer, or mishandling by the user after delivery.
- (2) Any malfunctions, defects, and/or damages caused by natural or man-made disaster.
- (3) If the product is used under any condition, environment, or method other than those specified in the specifications, catalogs, manuals, notes, and/or other documents.
- (4) Any malfunctions, defects, and/or damages caused by connected equipment and/or usage of inappropriate consumables and media.
- (5) If the product is repaired, remodeled, modified, or disassembled by a party other than DMC Co., Ltd, or if a serial number label cannot be verified.
- (6) Any failure, damage, or malfunction is deemed to be caused on your behalf.

This warranty covers only the product itself. No warranty is provided for damages, on-site repair, or replacement resulting from product failure.

All damaged parts are subject for replacement and freight will be charged.

13 Production Discontinuance

In the event of production discontinuance, an announcement will be made six months prior to the last possible order reception date.

14 Other

For comments or queries, feel free to contact us.

North South America area

technical-global@dush.co.jp

Asia Pacific area

technical-global-asia@dush.co.jp

Europe, Middle East, Africa area

technical-global-eu@dush.co.jp

FAQ

<https://www.dush.co.jp/english/support/faq/>

2nd Edition, July 2024

DMC Co., Ltd.

Business hours: 9:00a.m.~5:00p.m. (JST)

URL: <https://www.dush.co.jp/english/>

This document is protected by copyright law. Photocopying, duplicating, reproducing, and modifying of this product or document in part or by whole is prohibited.

Copyright(C) 2024 DMC Co., Ltd. All Rights Reserved

寸法許容差 呼び寸法 Nominal Dimensions	TOLERANCE
L ≤ 3	±0.4
3 < L ≤ 6	±0.48
6 < L ≤ 10	±0.58
10 < L ≤ 18	±0.7
18 < L ≤ 30	±0.84
30 < L ≤ 50	±1.0
50 < L ≤ 80	±1.2
80 < L ≤ 120	±1.4
120 < L ≤ 180	±1.6
180 < L ≤ 250	±1.85
250 < L ≤ 315	±2.1
315 < L ≤ 400	±2.3
400 < L ≤ 500	±2.5

SYM	改訂日 DATE	改訂内容 DESCRIPTION	ページ PAGE	担当 DESIGNED
	2024.01.24	新規図面登録	—	S. Takada

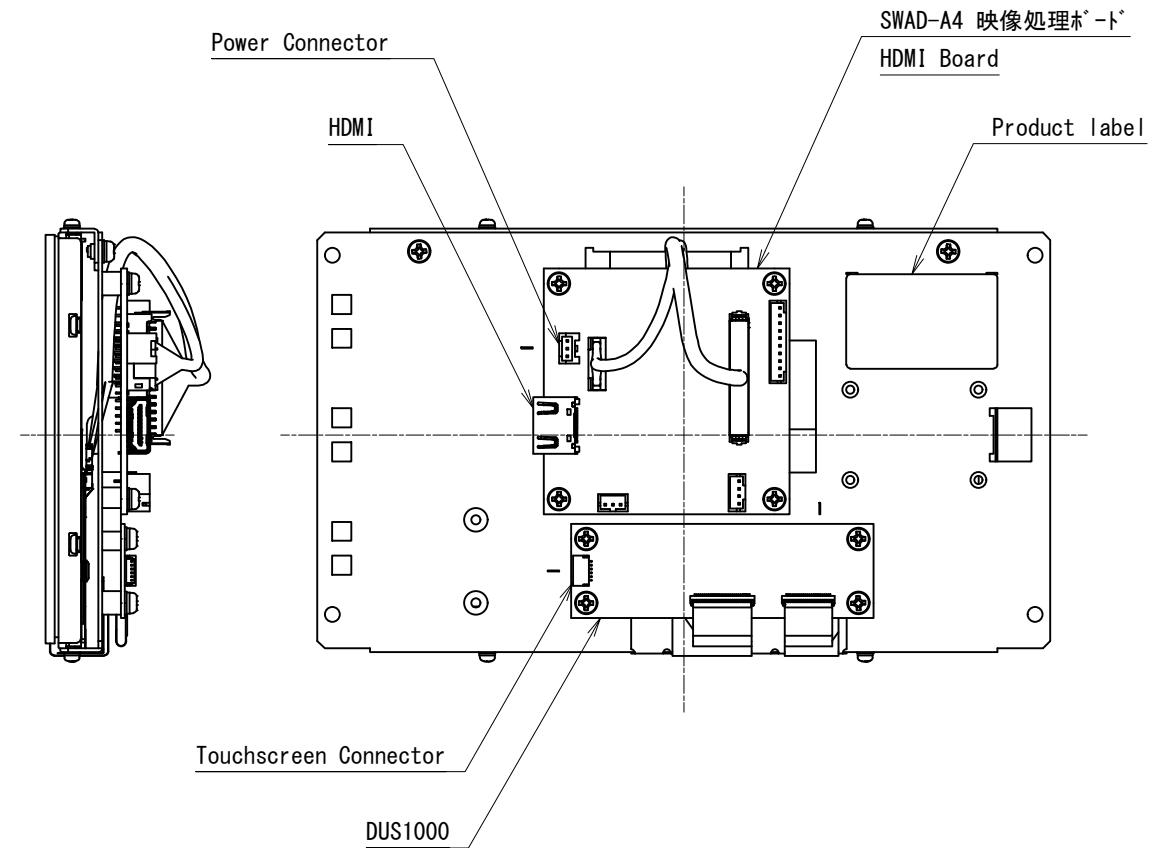
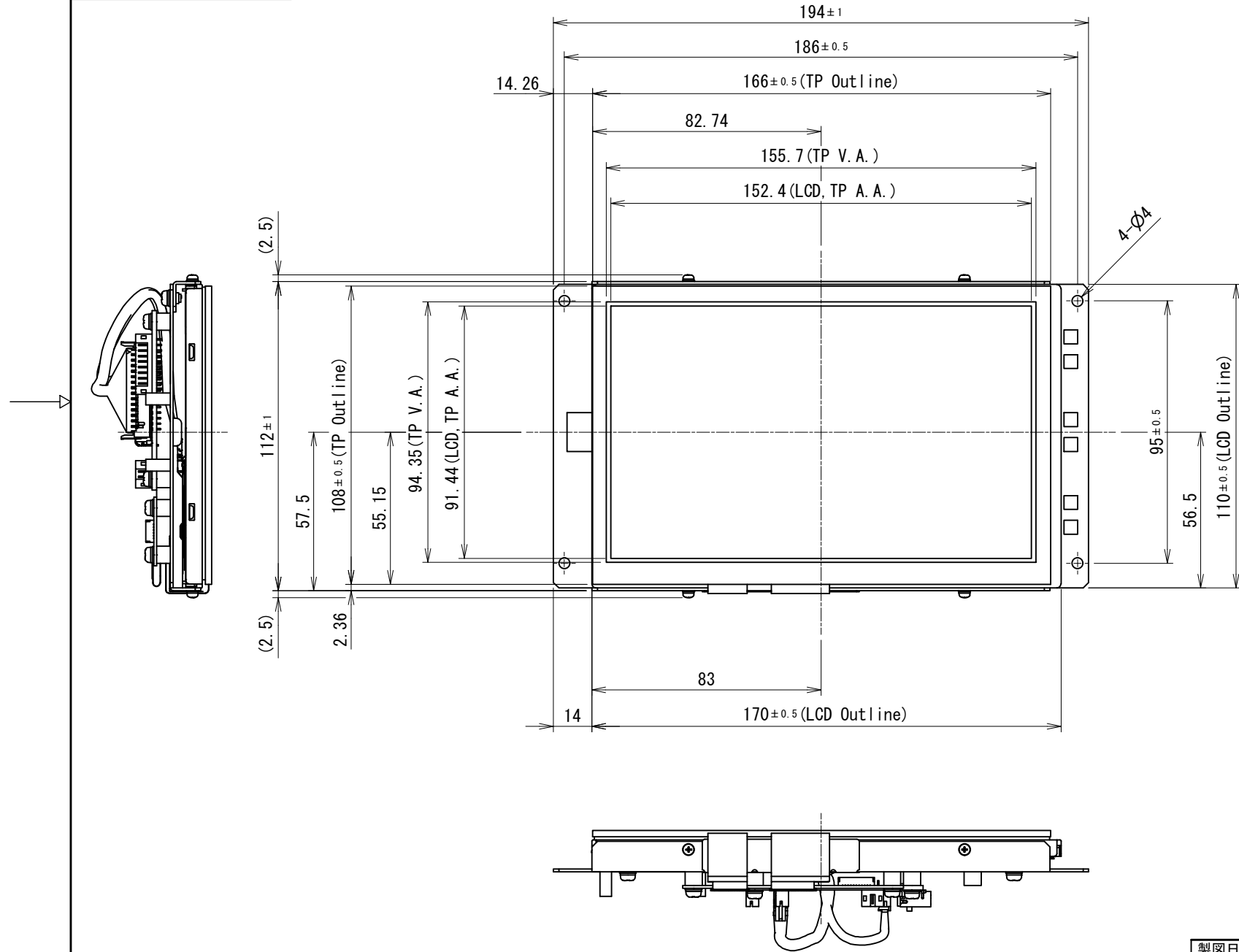
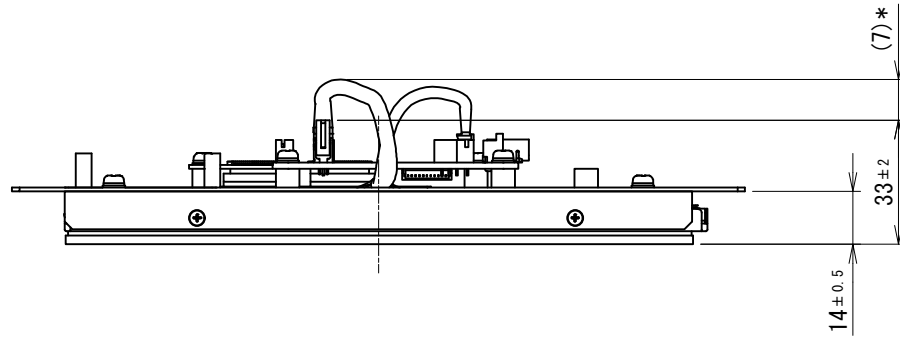

NOTES
1. 指示なき寸法公差は寸法公差表の通りとする。
Tolerance shall be of dimensional tolerance table unless specified otherwise.

製図日 ISSUED	2024.01.24	部署 SECTION	Technical Dept.	尺度 SCALE	CAD登録名 CAD FILE NAME	OUTLINE_TK-BPA07BWV-01A4	RoHS対応品 RoHS compliant
承認 APPROVED		検図 CHECKED		1:2	製品名 MODEL	TK-BPA07BWV-01A4	
		製図 DRAWN	S. Takada	単位 UNIT	図名 TITLE	OUTLINE	ページ PAGE
T. Okada	S. Yoshimoto	設計 DESIGNED	S. Takada	mm	図番 DWG No.	SM3-002448-10	1 / 1
DMC Co., Ltd.			A3				

Glass/Glass Structure Projected Capacitive Touch Screen, Mounting Guidance

Projected capacitive touch screen detects the touched locations by measuring the increased amount of the capacitance value between its electrodes. Once it is built into a system, capacitance couplings are continually yielded among the touchscreen, FPC tail, controller board and metal Chassis.

If surrounding environment changes or materials to alter the electrical field (a large capacitor, power-supply unit, LCD panel, or materials with high dielectric constant) is near, these external factors will adversely affect the function of the touch screen to detect the correct input positions.

At structure design, please refer to the mounting guidance below and ensure enough gap distances among each component in order to avoid the external factors described above.

- Refer to the drawing of the touch screen, and take into account the tolerances at structure design.
- Fix the touchscreen firmly so that the gap distances between the touchscreen and other components will not be affected by touching or will not change with the passage of time. An unexpected input may be caused if the gap is too narrow.
- In case of using capacitive sensor outside, the moisture may cause the trouble.
- In order to avoid the gap distance L1 from being changed with the passage of time, it is recommended to apply the adhesive tape onto all the 4 sides with no space (fully sealed) when gluing the touch screen.

The distance values indicated in this sheet are for reference only.

The appropriate distance values depend on touch screen size, LCD, chassis design and other factors.

Please confirm the appropriate distances with the actual products prior to fixing the chassis design.

Structure with Bezel

- It is recommended to use an insulating resin material for the bezel. Ensure the gap between the touch screen and front bezel (L4)
- If a metal material is used for the bezel, unintended capacitance couplings may occur on the periphery of the active area.
If a metal material is used for bezel, ensure the gap of approximately 2mm between touch screen and bezel (L2).
- In order to avoid the gap distance L1 from being changed with the passage of time, it is recommended to apply the adhesive tape onto all the 4 sides with no space (fully sealed) when gluing the touch screen.

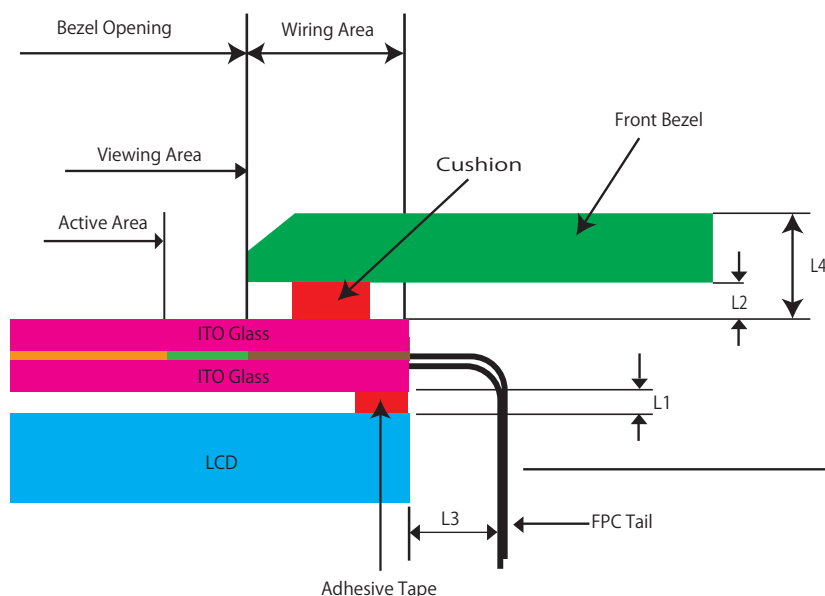

$L4 \geq 2\text{mm}$: Distance between touch screen and bezel surface

$L2 \geq 2\text{mm}$: If the bezel is metal, at least 2mm would be needed between the touch screen and bottom of the bezel.

$L1 \geq 1\text{mm}$: Distance between touch screen and LCD bezel

$L3 \geq 1\text{mm}$: Distance between LCD and FPC Tail

The FPC tail must not be forcibly stressed or bent too hard. The conduction in the insulated area and/or wire breaking may be caused. For the specifications of FPC bending, refer to the product specifications of the touch screen.

Flat-surface Structure (Covering glass is needed)

- In order to avoid the gap distance L1 from being changed with the passage of time, it is recommended to apply the adhesive tape onto all the 4 sides with no space (fully sealed) when gluing the touch screen.

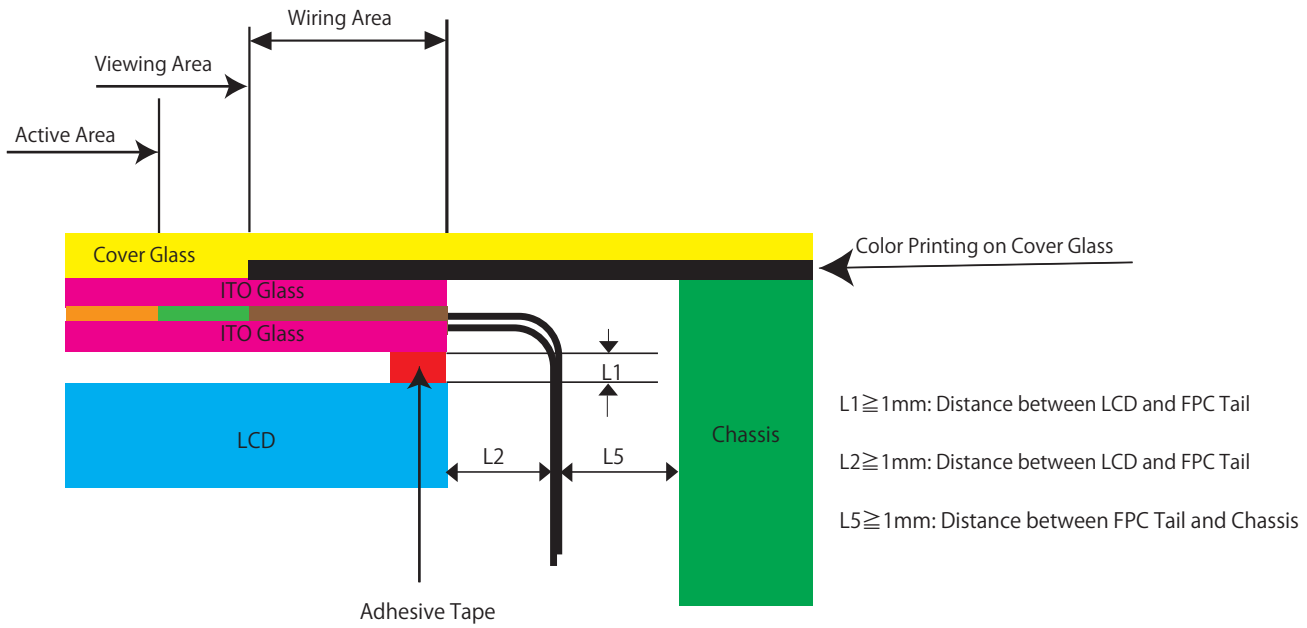

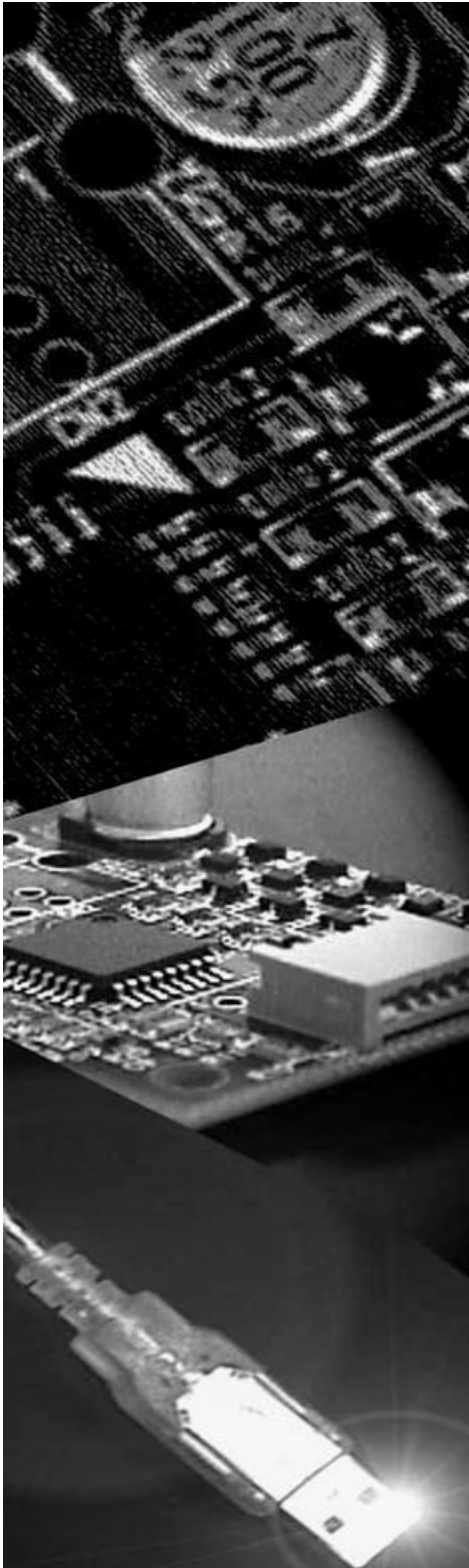

DMC Co., Ltd.

**Controller Board for Projected Capacitive Touch Screen
DUS1000 Product Specification**

Table of Contents

1. Applicable Product	2
2. Product Specification	2
2-1. Touch Screen Board Specification	2
2-2. Host Interface	3
2-3. Electrical Specification.....	3
2-3-1. Maximum Absolute Rating.....	3
2-3-2. DC Characteristics.....	3
2-4. Connector Pin Assignment	5
2-4-1. Connector Information.....	5
2-4-2. Connector Terminal.....	5
2-4-3. Input Equivalent Circuit of Reset Signal	6
3. Precautions	7
4. Change History	7
5. Warranty	10
5-1. Warranty Period.....	10
5-2. Warranty Target.....	10
5-3. Warranty Exceptions.....	10
6. Precautions for Use	11
6-1. General Handling.....	11
6-2. Others.....	11

Outline Dimensional Drawing

1. Applicable Product

This specification sheet is applied to DUS1000 touch screen controller board.

2. Product Specification

2-1. Touch Screen Board Specification

Item		Spec	Remark
Touch Detection Principle		Projected Capacitive	
Host Interface		USB Full-Speed UART	
Input Power-supply Voltage		5[V]±5[%]	
Operating Temp		-20 [°C] to 85 [°C]	No dew condensation
Storing Temp		-40 [°C] to 85 [°C]	No dew condensation
Main IC		MCU 1 [pcs]	
		Sensor IC 1 [pcs]	
Number of Electrodes	Electrode (X)	28	
	Electrode (Y)	18	
Coordinate Performance	Maximum Coordinate Number to Output	2 [Finger]	
	Report rate (1 finger)	100 [Hz]	*2
	Report rate (2 fingers)	100 [Hz]	*2
	Report rate (2 fingers at same axis)	100 [Hz]	*2
	Electrode resolution	256 [1/Electrode]	
	2 fingers minimum distance (X)	3.5 [Electrode]	21[mm]@6[mm]◇
	2 fingers minimum distance (Y)	3.5 [Electrode]	21[mm]@6[mm]◇
	Coordinate Accuracy (1 finger: high accuracy area)	max ±2%	*1
	Coordinate Accuracy (2 fingers: high accuracy area)	max ±4%	*1
	Coordinate Accuracy (1 finger: low accuracy area)	max ±5%	*1
	Coordinate Accuracy (2 fingers: low accuracy area)	max ±8%	*1
	Low accuracy area	3 [Electrode]	Specify area from the edge
Low Power Mode		Active / Suspend	
Calibration	Calibration function	Support	
	Calibration Time	10 - 15 [sec]	*3

*1 Touch contact size: φ10. The indicated coordinate accuracies are performances under a noise-free environment. The accuracy may significantly drop due to extrinsic noises.

*2 Report rate depends on CR values of the sensor glass. This specification is of the operation by 250KHz clock scan.

*3 Calibration Time varies according to size of the touch screen.

2-2. Host Interface

USB Interface

Item	Value	Note
Host Interface	USB 2.0 Full speed 12[Mbps]	
Power supply	Bus-powered	
Power type	Low power device	Under 100mA
VendorID/ProductID	0x0AFA / 0x07D2, or 0x0AFA / 0x07D3 (At firmware update: 0x0AFA / 0x07D0)	
Power save mode	USB Suspend mode (compliant to USB specification)	

Serial Interface

Item	Value	Note
Host Interface	UART Baud Rate 57.6[Kbps]	
Data bits	8	
Stop bit	1	
Parity check	None	

2-3. Electrical Specification

2-3-1. Maximum Absolute Rating

Item	Specifications			Unit	Note
	Min.	Typ.	Max.		
Touch Panel Power Supply	-0.3		6	V	

2-3-2. DC Characteristics

Board Consumption Current

Test Condition : TA = 25°C, VCC = 5V

Item	Specifications			Unit	Note
	Min.	Typ.	Max.		
Touch Panel Power Supply	4.75	5	5.25	V	
Normal operation mode		40		mA	
Suspend mode		500		uA	

IO Signal (TX, RX) DC Characteristics

Parameter	Specifications			Unit	Note
	Min.	Typ.	Max.		
Input High Voltage	2.0		VDD +0.2	V	VDD=5.25V
Input Low Voltage	-0.3		0.8	V	VDD=4.75V
Output High Voltage	2.4		-	V	VDD=4.75V
Output Low Voltage	-		0.45	V	VDD=5.25V

USB Signal (D+, D-) DC Characteristics

Parameter	Specifications			Unit	Note
	Min.	Typ.	Max.		
Input High Voltage	2.0		-	V	
Input Low Voltage	-		0.8	V	
Output High Voltage	2.8		3.6	V	
Output Low Voltage	0		0.3	V	

IO Signal (Reset) DC Characteristics

Item	Specifications			Unit	Note
	Min.	Typ.	Max.		
Input High Voltage	0.7VDD	5	5.25	V	
Input Low Voltage	-0.5		0.3VDD	V	

2-4. Connector Pin Assignment

2-4-1. Connector Information

Connector Number	Model Number	Maker
CN1	FH19SC-24S-0.5SH(0.5)	HIROSE
CN2	FH19SC-30S-0.5SH(0.5)	HIROSE
CN3	SM06B-SRSS-TB	JST
CN4	SM11B-SRSS	JST

2-4-2. Connector Terminal

Connector Number	Terminal Number	Terminal Name	Description
CN1			Connector for touch sensor, 24 pins
CN2			Connector for touch sensor, 30 pins
CN3	1	Vbus	USB power input
	2	D-	USB D-
	3	D+	USB D+
	4	GND	USB GND
	5	RESET	Reset Terminal Active L Minimum Pulse Width 100μS
	6	GND	Reset GND
CN4	1	ICE_CK	Unused
	2	ICE_DAT	Unused
	3	RSTn	Reset Signal Active L Minimum Pulse Width 100μS
	4	Tx	UART Communication (5VTTL Level) DUS Board → Host Computer
	5	Rx	UART Communication (5VTTL Level) Host Computer → DUS Board
	6	SCL	Unused
	7	SDA	Unused
	8	GPIO1	Unused
	9	Vcc_IN	DC Power Input
	10	ICE_Vcc	Unused
	11	GND	Power Ground

2-4-3. Input Equivalent Circuit of Reset Signal

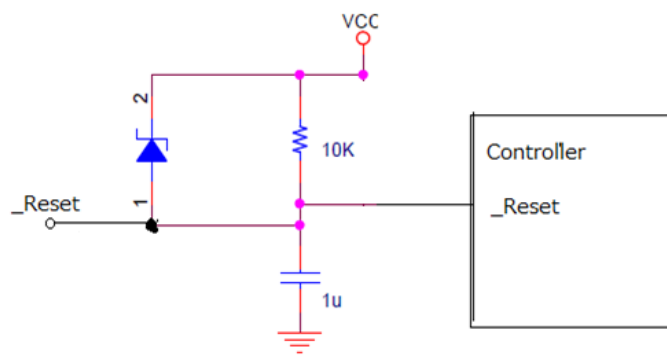

3. Precautions

Operation may become unstable, depending on the surrounding environment.

Do not use the controller under environments that affect capacitance values (The affecting factors are such as power-supply noises).

The application tool, TPOffset must be executed before operating DMC's touch screens of capacitive multi-touch type (EXC series and DUS series) with the DUS series controller.

TPOffset is the application software executable on Windows. It can be downloaded from the DMC's website below.

DMC's website: TPOffset download page

<http://www.dmccoltd.com/english/download/tpoffset.asp>

4. Change History

Ver0.1 (June 12, 2012)

Provisional product specification was issued.

Ver0.2 (June 29, 2012)

2-1. Touch Screen Board Specification Main IC : Changed a description.

2-1. Touch Screen Board Specification Number of Electrodes (Y) : Fixed 17 to 18

2-5-1. Connector Information : (No Mount) is added.

Ver1.0 (October 1, 2012)

First Release

Changes from the Ver0.2 are as follow.

2-1. Touch Screen Board Specification....Interface UART was added.

2-1. Touch Screen Board Specification....Operating / Storing Temp was added.

2-1. Touch Screen Board Specification....Calibration Time Max was changed to TYP.

2-1. Touch Screen Board Specification....(Max) was deleted from Number of Electrodes.

2-1. Touch Screen Board Specification....The Item "DFU" was deleted.

Outline Dimensional Drawing was moved to the last page.

2-4. Connector Pin Assignment CN5 was deleted.

2-4-2. Connector Terminal....Clerical mistakes under Terminal Name and Description were corrected.

2-4-2. Connector Terminal...The descriptions for the unused terminals on CN4 was changed to "Unused".

Ver1.1 (November 2, 2012)

Changes from ver1.0

2-1. Touch Screen Board Specification.....Electrode resolution 512 → 256 (Clerical mistake was corrected.)

2-2. Host Interface.....USB Interface VendorID/Product ID was changed (Specification changed).

Ver1.2 (April 23, 2013)

Changes from the ver1.1

3. Precautions The description about the TPOffset software tool was added.

Address: Nisseki Takanaawa Bldg., → Takanaawa Sengakuji Bldg.,(The building name was changed).

Ver1.3(August 28, 2013)

Changes from the ver. 1.2

2-1. Touch Screen Board Specification

2 finger minimum distance (X): 18[mm]@6[mm]◇ was corrected to 21[mm]@6[mm]

2 finger minimum distance (Y): 18[mm]@6[mm]◇ was corrected to 21[mm]@6[mm]

Calibration Time: TYP 5 [sec] was changed to 10 - 15 [sec]

Calibration Time: [*3 Calibration Time varies according to size of the touch screen.] was added.

2-2. Host interface

USB Interface

VendorID/ProductID :

changed to 0x0AFA / 0x07D2, (At firmware update: 0x0AFA / 0x07D0)

2-4-2. Connector Terminal

CN3 RESET: [Active L] and [Minimum Pulse Width 100μS] were added.

CN4 RSTn: [Active L] and [Minimum Pulse Width 100μS] were added.

CN4 Tx: [DUS Board → Host Computer] was added.

CN4 Rx: [DUS Board → Host Computer] was added.

2-4-3. Input Equivalent Circuit of Reset Signal was added.

Dimensional Drawing

Updated from Rev.1 to Rev.2 (Changed content is as below)

“FG” notations were added.

Ver1.4(April 9, 2014)

Changes from the ver. 1.3

2-2. Host interface: VendorID/ProductID (0x0AFA / 0x07D2) was added.

2-3-2.DC Characteristics: IO Signal (Tx ,Rx, Reset) was changed to (Tx, Rx)

2-3-2.DC Characteristics: IO Signal (Tx ,Rx) The numerical value was corrected. (Clerical mistake was corrected.)

2-3-2.DC Characteristics: IO Signal (Reset) was added.

2-4-2.Connector Terminal: CN4 Rx: Fixed [DUS Board → Host Computer] to [Host Computer →DUS Board]

Ver1.5 (October 27, 2014)

Dimensional Drawing Updated from Rev.2 to Rev.3 : Tolerances were added.

Ver1.6 (June 25, 2015)

Change from ver1.5

2-1Touch Screen Board Specification Description of the Coordinate Accuracy changed.

Ver1.7 (December 24, 2015)

Change from ver1.6

3. Precaution

The application tool, TPOffset must be executed before operating DMCng on the surrounding environment. The accuracy may significantly drop due to extrinsic controller.

→ The application tool, TPOffset must be executed before operating DMC's touch screens of capacitive multi-touch type (EXC series and DUS series) with the DUS series controller.

(Correction of literal error)

Ver1.8 (April 26, 2019)

Change from ver1.7

2-1Touch Screen Board Specification General Tolerances were added.

5. Warranty

5-1. Warranty Period

- § The warranty period is limited to 1 year from the date of shipping. The warranty for the initial deflection such as appearance deflection is limited to 1 month.
- § Any defected parts under proper use will be examined by the supplier and replaced by the new parts if the deflection is considered to be caused by the supplier.
- § The replacement is subject to be included in the next lot.

5-2. Warranty Target

- § The warranty only covers the product itself and does not cover any damage to others caused by using this product. Onsite repair or replacement is not supported.
- § We will do our best for delivery problem and product deflections, but the warranty for the production line is not covered.

5-3. Warranty Exceptions

Following conditions are not covered with the warranty and subject to charge.

- § Any malfunctions and damages during transportation and transfer by the user.
- § Any malfunctions and damages caused by a natural disaster or a fire.
- § Any malfunctions and damages caused by static electricity
- § Any malfunctions and damages caused by the failure of the associated equipment.
- § If the product is remodeled, disassembled or repaired by the user.
- § If the product is glued onto the equipment and uninstalled.
- § Any malfunctions and damages caused by an improper usage and handling against the specifications and notes.

6. Precautions for Use

6-1. General Handling

- § Keep the product away from any conductive objects while in use.
- § Do not touch the conductive part of the product to avoid being damaged by the electrostatic discharge. Follow the proper procedure for handling.
- § Keep the product in the proper storing environment and avoid any load to the product.
- § Do not use or store the product in the severe condition like following:
 - Wet environment or a condition where the product is likely to get wet. Where dew condensation is likely to occur. Near solvent or acid.
- § Do not take apart or alter the product.

6-2. Others

- § The contents of this document are subject to change without notice.
- § The manufacturer or sales representatives will not be liable for any damages or loss arising from use of this product.
- § This product is intended for use in standard applications (computers, office automation, and other office equipment, industrial, communications, and measurement equipment, personal and household devices, etc.) Please avoid using this product for special applications where failure or abnormal operation may directly affect human lives, or cause physical injury or property damage, or where extremely high levels of reliability are required (such as aerospace systems, vehicle operating control, atomic energy controls, medical devices for life support, etc.).
- § Any semiconductor devices have inherently a certain rate of failure. The user must protect against injury, damage, or loss from such failures by incorporating safety design measures into the user's facility and equipment.

DUS1000 Product Specification
Ver1.8 issued on December 24, 2019
©2019 DMC Co., Ltd.

This document can be freely distributed, but any alternation to this document is prohibited.



DMC Co., Ltd.
<http://www.dmccoltd.com/english/>
11F Takanawa Sengakuji Ekimae Bldg., 2-18-10 Takanawa, Minato-ku, Tokyo 108-0074, Japan
Phone: +81-3-6721-6731 (Japanese), 6736 (English) Fax: +81-3-6721-6732

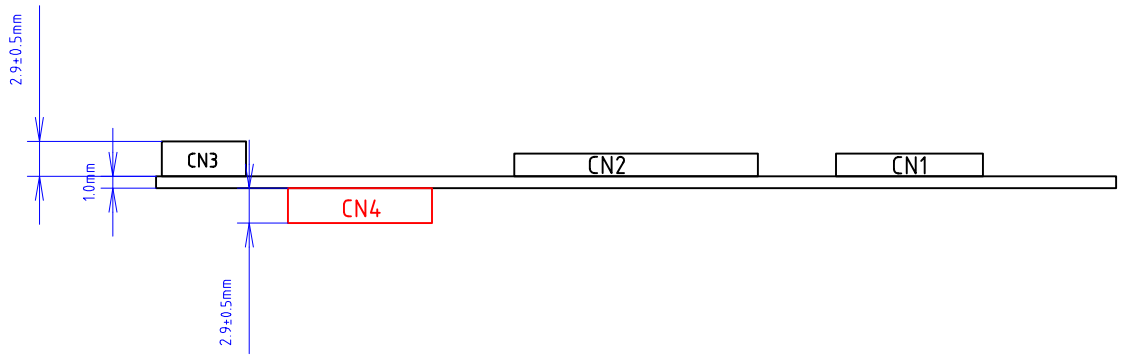
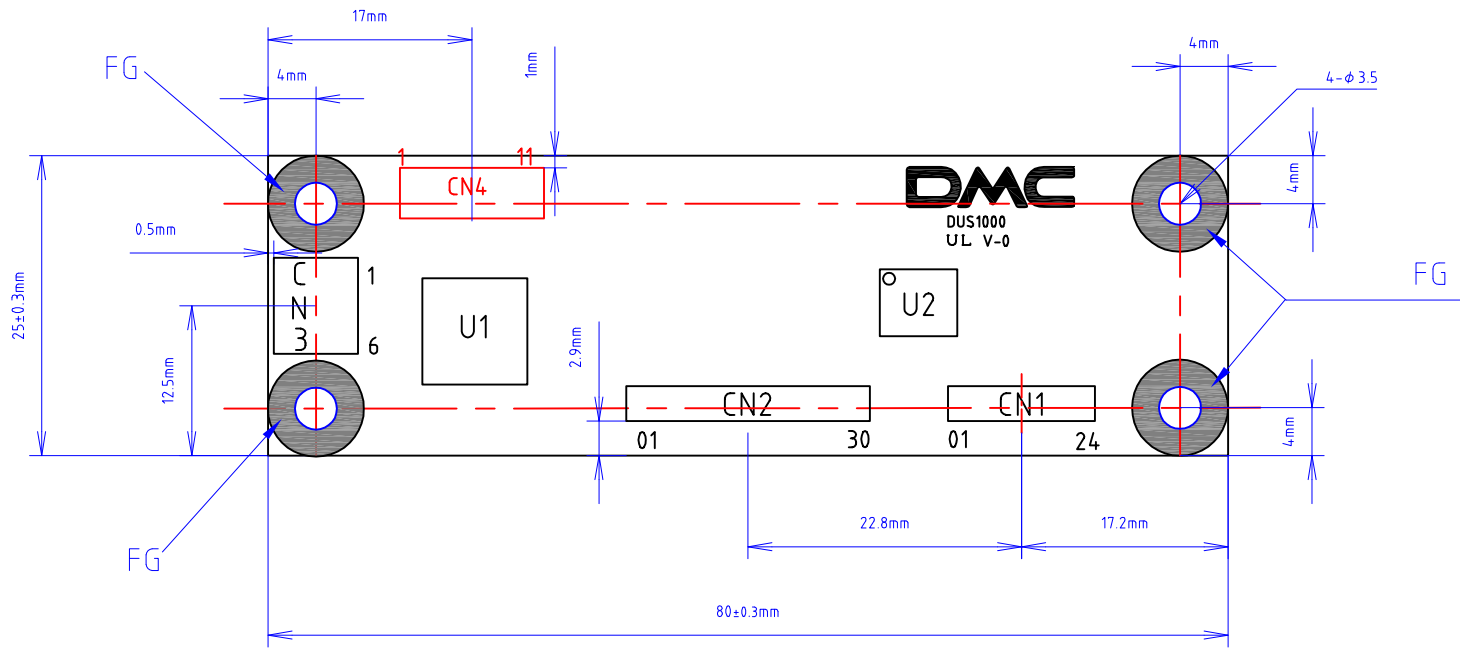

TOLERANCE = $\pm 0.3\text{mm}$
 UNIT = mm

Date	P/N
December 9, 2016	DUS1000
Name	
Dimensional Drawing	Rev.4
DMC Co., Ltd.	

Appearance inspection standard (1)

1.1 Inspection condition

Inspection Distance : 35 ± 5 cm

View Angle : Inspection under non-operating condition : $\pm 30^\circ$

Ambient Illumination : 500~2000 lux

Inspection time : 3~5 seconds

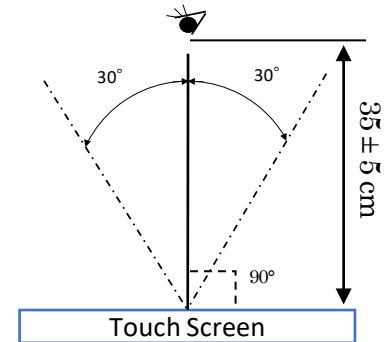

1.2 Scratch, dust (W = width, L = length, D = average diameter = (longest + shortest) / 2))

Total defects on each panel.

【 14 inches < Size ≤ 22 inches 】 Within 10 pcs / panel

【 < Size ≤ 14 inches 】 Within 7 pcs / panel

Item	Width(mm)	Length(mm)	Acceptable Numbers
Linear (Foreign substance/scratch/ transparent defects) *1 Defects over 0.2mm in diameter will be judged in circular.	$0.15 < W \leq 0.2$	$L \leq 10$	Up to 4pc per product
	$0.1 < W \leq 0.15$	$L \leq 20$	Up to 6pc per product
	$W \leq 0.1$	Acceptable	Acceptable
Circular (Foreign substance/scratch/ transparent defects) *1	$0.5 < D \leq 0.7$		Up to 1pc per product
	$0.3 < D \leq 0.5$		Up to 6pc per product
	$D \leq 0.3$		Acceptable

*1 Transparent defects mean, e.g. bubble, lint etc...

(Lint is the defect that is different transparent from other part due to the elevating surface by printing over foreign substance.)

- Stains are acceptable as long as they are not clearly outlined and are not noticeable.
- Applied only in the Viewing Area.

Scratches or dusts in the outside of the Viewing Area are acceptable unless the electrical characteristics are affected.

Product	LCD Modules with Capacitive Glass Sensor Touchscreen	Document No.	22G4GX-00002E-0
---------	--	--------------	-----------------

Appearance inspection standard (2)

1.3 Chip(cover glass , touch panel) (t = Glass thickness)

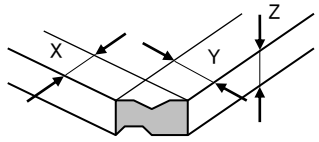
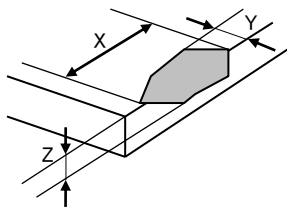
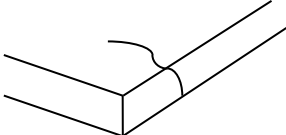
Item	Size(mm)		Acceptable Numbers
Corner		X	$1.0 \leq X \leq 2.0$
		Y	$1.0 \leq Y \leq 2.0$
		Z	$\leq t$
Other than at corners		X	≤ 5.0
		Y	$1.0 \leq Y \leq 2.0$
		Z	$\leq t/2$
Progressive Crack			Not acceptable

1.4 Appearance criteria for color-printed area of covering glass (judged from surface view)

Item	Defect contents	Acceptable range	
Color Peeling	Color print coming off	Unacceptable	
Color Lacking	Color print partly missing	Unacceptable	
Color Running	Ink bleed	The defect should not be over edge face	
Scratch	Scratch on color-printed part	Base glass should not be exposed	
Color Unevenness	Color thickness is uneven	Should be no color unevenness that can be easily detected. (should not be detectable by gaze for 4 - 6 seconds)	
Pinhole through to the base glass, Adhering foreign substance which is different color from the printing	a : $0.2 \text{ mm} < D \leq 0.3 \text{ mm}$ b : $D \leq 0.2 \text{ mm}$	Acceptable quantity	Total acceptable quantity
		a : 2pcs in $\phi 30 \text{ mm}$ b : Acceptable	Up to 5pc per product
Tilt/Misalignment	—	Should be within tolerances indicated by the drawing	

Product	LCD Modules with Capacitive Glass Sensor Touchscreen	Document No.	22G4GX-00002E-0
---------	--	--------------	-----------------